

ITEM NUMBER	CATALOG NUMBER	2 CONDUCTOR RANGE				BOLT CIRCLE DIA. IN INCHES	APPROX. SHIP WEIGHT IN LBS	DIMENSIONS IN INCHES					
		CABLE		IPS				B	4 G	4 H	3 J	K	W
		MIN.	MAX.	MIN.	MAX.								
323190	LH283	#6 SOLID	4/0 STRANDED	-	-	3 [76]	1.7	1.69 [43]	1.25 [32]	2.56 [65]	3/8"-16	0.56 [14]	1.94 [49]
323220	LH343	2/0 STRANDED	500 Kcmil	1/4" (0.540 [14] DIA.)	1/2" (0.840 [21] DIA.)	3 [76]	2.0	1.38 [35]	1.31 [33]	2.44 [62]	3/8"-16	0.56 [14]	4.25 [108]
25015674	LH345	2/0 STRANDED	500 Kcmil	1/4" (0.540 [14] DIA.)	1/2" (0.840 [21] DIA.)	5 [127]	3.0	1.38 [35]	1.38 [35]	2.50 [64]	3/8"-16	0.69 [17]	2.19 [56]
323614	LH453	550 Kcmil	1250 Kcmil	1/2" (0.840 [21] DIA.)	1" (1.315 [33] DIA.)	3 [76]	3.0	1.63 [41]	1.50 [38]	3.19 [81]	1/2"-13	0.56 [14]	4.44 [113]
50017101	LH455	550 Kcmil	1250 Kcmil	1/2" (0.840 [21] DIA.)	1" (1.315 [33] DIA.)	5 [127]	4.0	1.63 [41]	1.50 [38]	3.19 [81]	1/2"-13	0.69 [17]	4.38 [111]
25014217	LH483	1300 Kcmil	2000 Kcmil	1" (1.315 [33] DIA.)	1-1/4" (1.660 [42] DIA.)	3 [76]	3.5	1.63 [41]	1.81 [46]	3.38 [86]	1/2"-13	0.56 [14]	4.38 [111]
25014211	LH485	1300 Kcmil	2000 Kcmil	1" (1.315 [33] DIA.)	1-1/4" (1.660 [42] DIA.)	5 [127]	4.5	1.63 [41]	1.81 [46]	3.38 [86]	1/2"-13	0.69 [17]	4.38 [111]

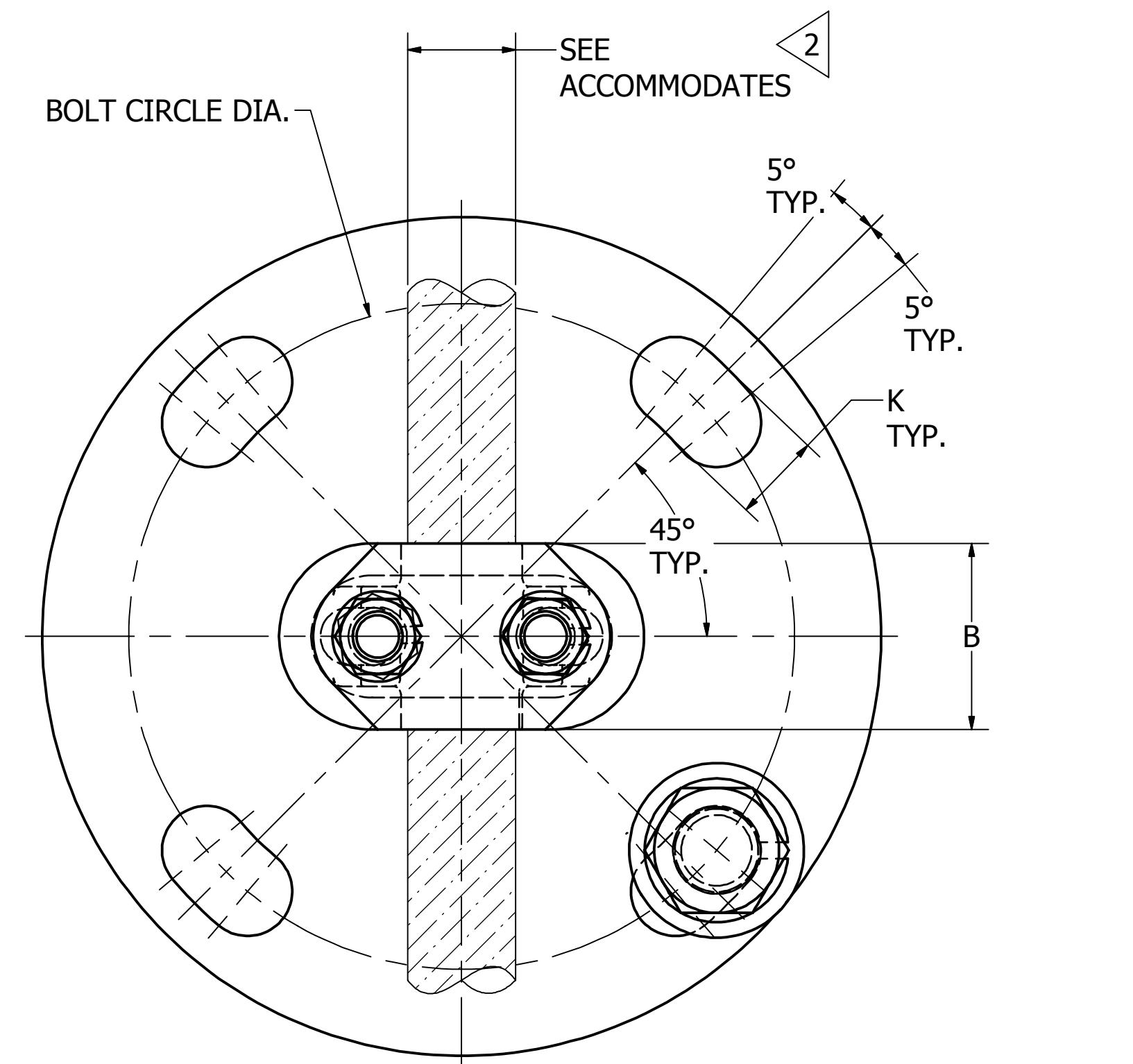

6 CAP MOUNTING HARDWARE KIT				
BOLT CIRCLE DIA. IN INCHES	CATALOG NO.	DESCRIPTION	QTY	NOMINAL INSTALLATION TORQUE
3 [76]	MTG3C4	1/2-13 X 1.00 GALV STL HEX HEAD BOLTS	4	480 IN-LB [55 Nm]
		1/2 GALV STL SPLIT LOCK WASHER	4	
		1/2 GALV STL FLAT WASHER	4	
5 [127]	MTG5C4	5/8-11 X 1.25 GALV STL HEX HEAD BOLTS	4	660 IN-LB [75 Nm]
		5/8 GALV STL SPLIT LOCK WASHER	4	
		5/8 GALV STL FLAT WASHER	4	

7 BASE MOUNTING HARDWARE KIT				
BOLT CIRCLE DIA. IN INCHES	CATALOG NO.	DESCRIPTION	QTY	NOMINAL INSTALLATION TORQUE
3 [76]	MTG3B4	1/2-13 X 1.50 GALV STL HEX HEAD BOLTS	4	480 IN-LB [55 Nm]
		1/2 GALV STL SPLIT LOCK WASHER	4	
		1/2 GALV STL FLAT WASHER	4	
		1/2 GALV STL NUT	4	
5 [127]	MTG5B4	5/8-11 X 1.75 GALV STL HEX HEAD BOLTS	4	660 IN-LB [75 Nm]
		5/8 GALV STL SPLIT LOCK WASHER	4	
		5/8 GALV STL FLAT WASHER	4	
		5/8 GALV STL NUT	4	

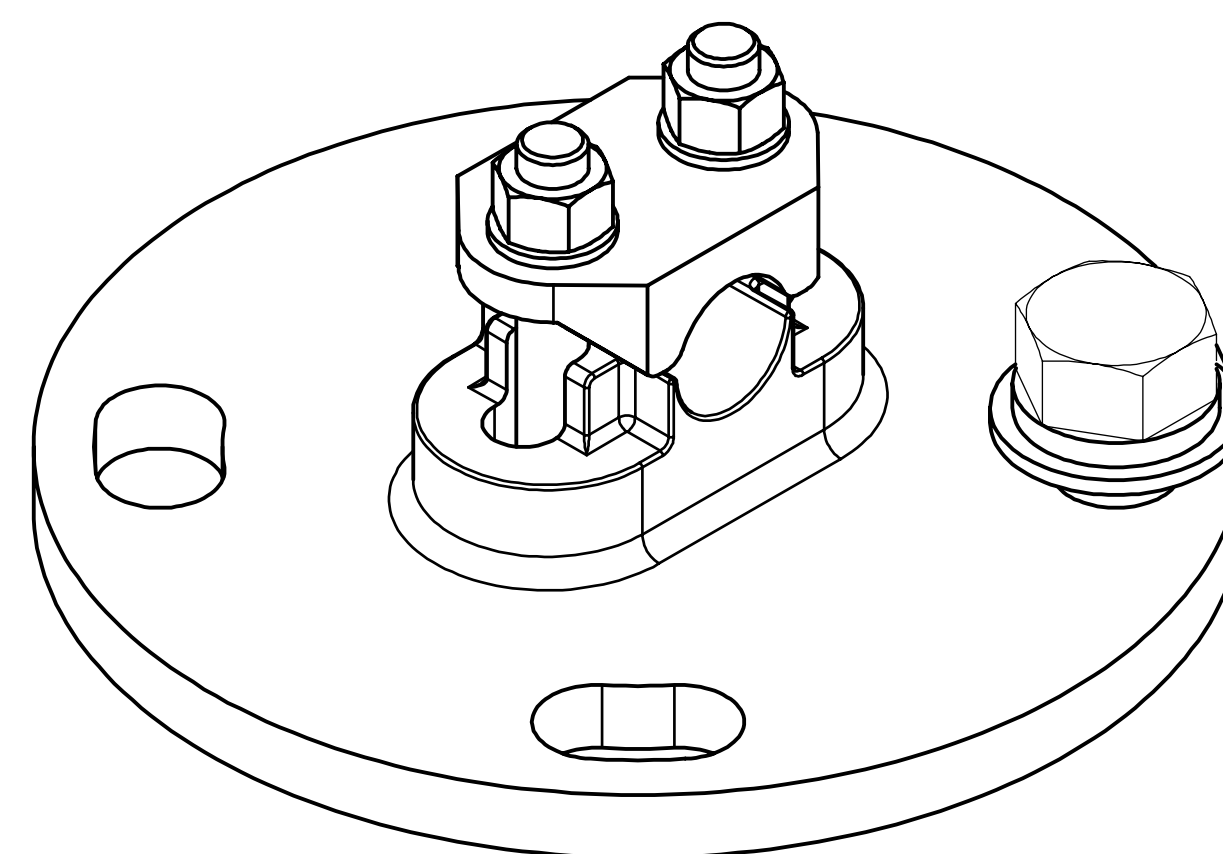
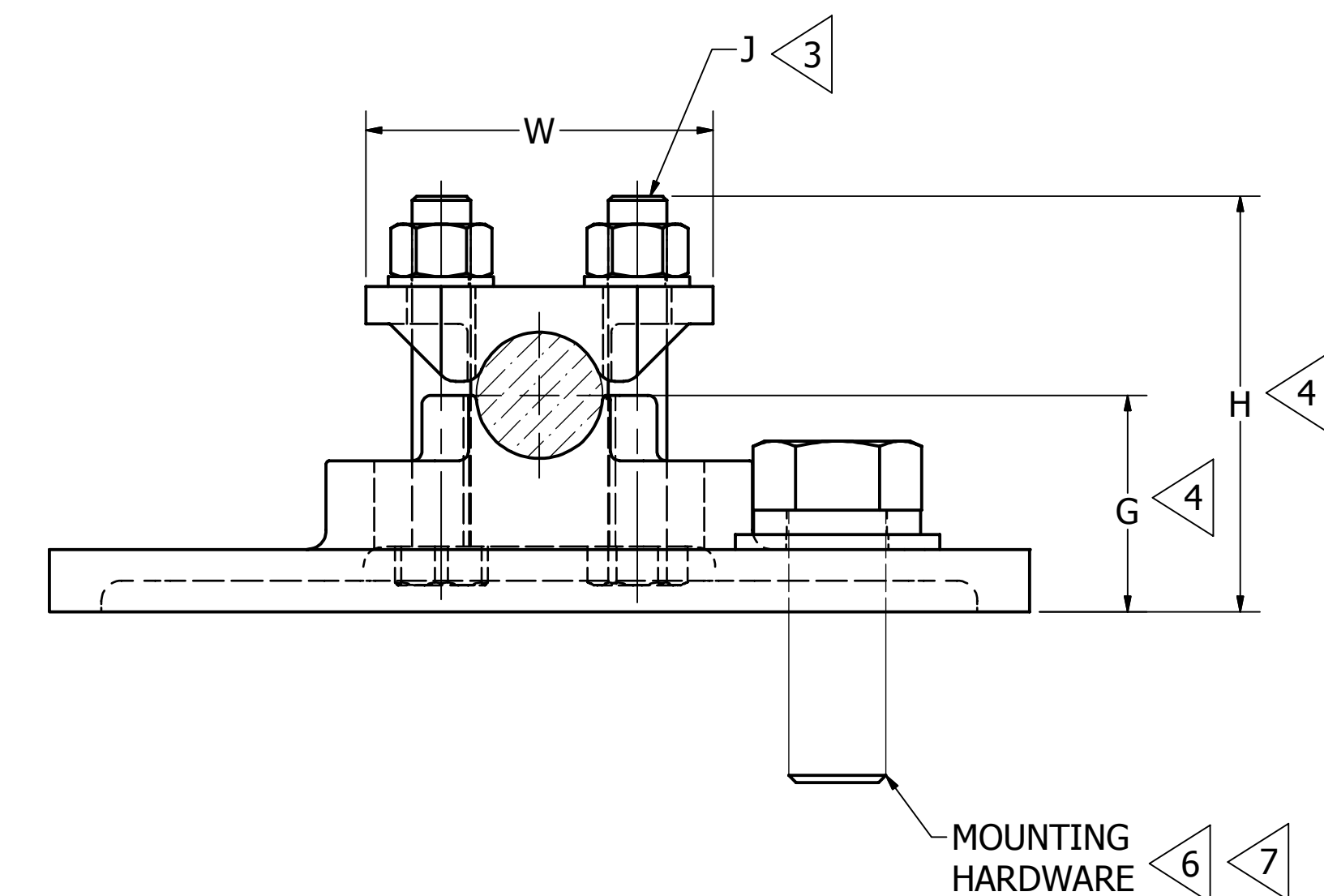

3D VIEW

NOTES:

- MATERIAL
 - CONNECTOR : CAST COPPER ALLOY
 - CLAMPING HARDWARE : SILICON BRONZE
 - MOUNTING HARDWARE : GALVANIZED STEEL
- ACCOMMODATES : SEE TABLE
- RECOMMENDED TIGHTENING TORQUE:
 - 3/8" SILICON BRONZE HARDWARE - 240 LB-IN [28 Nm]
 - 1/2" SILICON BRONZE HARDWARE - 480 LB-IN [55 Nm]
- DIMENSION WITH MAXIMUM CONDUCTOR IN PLACE
- DIMENSIONS IN BRACKETS [] DENOTES METRIC UNITS [SI UNITS] AND ARE ROUNDED TO THE NEAREST WHOLE NUMBER. UNLESS OTHERWISE SPECIFIED THESE UNITS SHALL BE USED FOR REFERENCE ONLY.
- MOUNTING HARDWARE KIT IS SUPPLIED AS STANDARD.
- SPECIFY BASE MOUNTING HARDWARE, IF REQUIRED, BY ADDING SUFFIX "-B" TO THE CATALOG NUMBER. (SEE TABLE - BASE MOUNTING HARDWARE KIT) EXAMPLE : LH283B

TO ORDER BURNDY® PRODUCTS CALL		BUS SUPPORT	
UNITED STATES 1-800-346-4175 (LONDONDERRY, NH)		ITEM NO: SEE TABLE	
CANADA: 1-800-361-6975 (QUEBEC) 1-800-387-6487 (ALL OTHER PROVINCES)		CAT. NO: SEE TABLE	
FOR PRODUCT INFO: http://www.burndy.com		DRAWN BY: M MOHAN 12/28/2012	
		CHECKER: S PANDIAN 12/28/2012	
		DSN APRVL: R LAVOIE 1/14/2013	
		MFG APRVL: --	
		QA APRVL: J HILLMAN 1/23/2013	
		MKT APRVL: V TORRES 1/17/2013	
		PROD FAM: SUBSTATION	
		PROJECT #: --	
		SIZE: D	
		DOCUMENT TYPE: SALES	
		REL LEVEL: Released	
		DRAWING NO: SA039214-01	
		SHEET 1 OF 1	
		REV: A	

REV	DATE	DESCRIPTION	ECO	BY	CHK.
A	12/21/2012	REDRAW SALES DRAWING SA039214-01	29903	MM	SP